

CREFORM AGVs... SIMPLE YET SOPHISTICATED. TITE-SPACE AGV TUGGER SERIES



*Unit shown with optional equipment

A Creform BST AGV works as an automated tugger, traveling along a magnetic tape guidepath, slipping under a stationary cart, extending a tow pin into the cart's frame and then conveying it to a designated workstation or unload point. After disengaging from the cart, it travels to its next assignment. One BST AGV has the ability to mobilize multiple carts or a series of BSTs can manage an entire fleet.

The Creform NSI model offers the most sophisticated control system available in BST style AGVs and it's manufactured in the U.S.A. The NSI model is programmable and can control 50 courses with up to 128 commands for each. Course programming can be accomplished with PC or an HMI (Human Machine Interface) touchscreen located on the front of the unit. Programs can be downloaded via USB memory, Ethernet cable or RF (requires optional equipment). It's available with an optional onboard RF communication device for traffic management, and just like all Creform BST units it responds to tape commands on the floor. For safety, the NSI model has all standard Creform safety devices plus a new laser scanner that has emergency stop, temp stop and temp slow settings in 16 view sets.

- Run-Ready with prompt shipment from stock. Made in USA.
- PLC with HMI touchscreen with easy access control box.
- 50 course 128 command control, programming by PC or HMI.
- Onboard RF for traffic management. (Optional)
- Safety — audible warning, flashing light, LED lights, obstacle sensor, non-contact laser bumper and e-stop (emergency stop, temp stop, temp slow, 16 view sets), safety category 3, 270° scanning capability.
- 24 Volt Power — full shift run under capacity load typical. Quick exchange battery tray & quick connector. Auto charge optional.
- Easy access engage/disengage lever.
- Follows magnetic tape guidepath. Free navigation capable.
- RFID reader for command initiation. Command tapes initiate AGV functions such as speed changes, turns and extend/retract tow pin.
- Standard 8 bit optical communication device. Often used for remote starting, course selection, charging, etc.
- Service & Support: Programming, plus cart/structure designs, kitting or assembly assistance along with route layout installation available from Creform.
- Opportunity charge module located in center position on path.

Sample HMI Screens

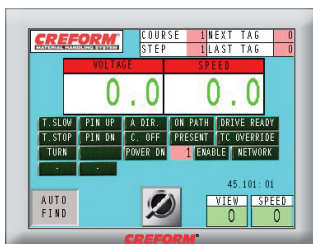

Auto Operation

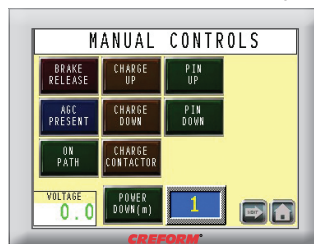

Manual Operation



Course Program



I/O Monitor

TITE-SPACE AGV TUGGER SERIES

SPECIFICATIONS

Part number	CA-Z50060-K9	CA-Z33090-K9
Speed range	4-50m/min 13-164ft/min	3-33m/min 10-108ft/min
Load capacity	600kg/1320lb	900kg/1980lb
Draw bar	26kg/57lb	39kg/86lb
Unit weight	74kg/163lb with batteries	96kg/212lb with batteries
Direction	Forward only, 90° & 180° turn capability, Temporary off tape travel forward or reverse up to 10m/33ft	
Battery type	24V DC, (2) TPPL or AGM batteries	
Safety devices	16 channel music box, LED lights, 16 view obstacle sensor, non-contact laser bumper, e-stop, safety PLC, CAT 3 rated	
Braking system	Regenerative braking, electromechanical emergency & parking brake	
Minimum turn radius	400mm/15.7"	
Control method	Magnetic command tapes, RFID tags, 50 course PLC with HMI, WiFi capable, onboard RF for traffic management (optional)	
Guidepath	50mm wide Creform magnetic tape and/or 6mm wide embedded strip	
Floor condition	Height slope 1% or less, step 2mm or less; trough 10mm or less Surface roughness 10mm or less between min & max	
Usage conditions	Indoor only; 32-140°F, 0-40°C; 30-80% humidity - no dew formation	
Tow pin	30mm shaft OD / approximately 50mm stroke / spring loaded	

*Capacity depends on floor conditions and caster selection on the cart.
Concept: subject to change.



A single BST AGV can manage an entire fleet of sequenced parts carts.

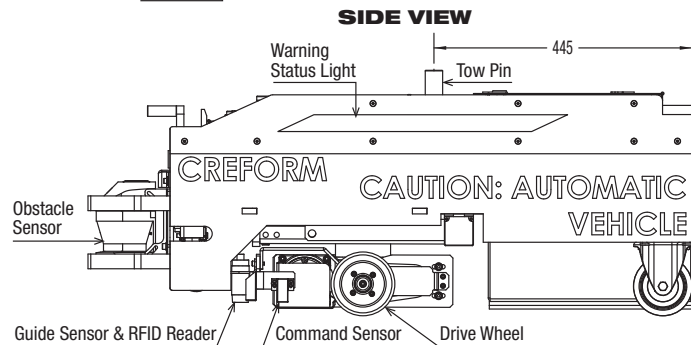
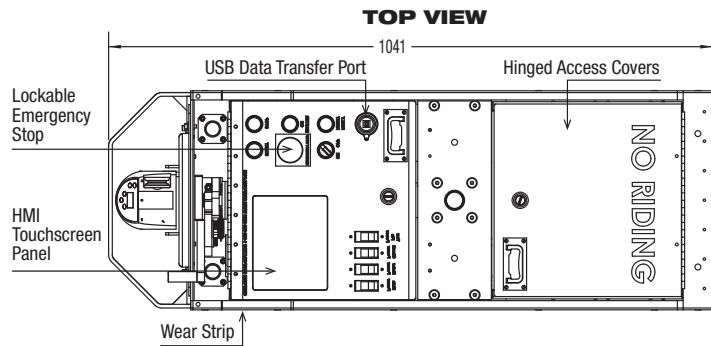
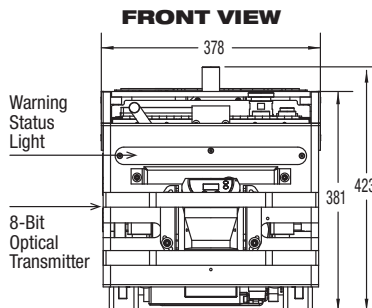

ISO 9001:
2015 CERTIFICATION

CREFORM® **MATERIAL HANDLING SYSTEMS**

www.creform.com
800-839-8823

Greer, South Carolina
Ph 864-989-1700 • Fax 864-877-3863
SCsales@creform.com

Novi, Michigan
Ph 248-926-2555 • Fax 248-668-6650
MIsales@creform.com

Georgetown, Kentucky
Ph 502-863-4506 • Fax 502-530-1310
SCsales@creform.com